

# Airturbo

Zones: 1 and 2



## Product Overview

**The Airturbo, originally used to meet the rigorous requirements of underground explosion proof lighting for coal mines, is BASEEFA certified for use in Zones 1 and 2 industrial hazardous areas, typically in oil and petrochemicals industries for tank cleaning and pipeline inspections.**

Once connected to a suitable air supply, continuous output of high quality general illumination is produced, even under water. The A-0444 is fitted with a bay light type head providing all round illumination when suspended in the work area and the moulded ball glass containing the bulb is surrounded by a protective polycarbonate dome. The A-0445 provides a flood beam giving a well diffused 30° angle of light with the standard matt reflector, or with a polished reflector, a highly concentrated spot light. The lamp has a 15mm toughened glass lens for high impact strength and pressure resistance.

Housings are spark free cast brass with a forged brass safety hook, all nickel-plated. The generator is a compressed air driven turbo-alternator of simple design and robust construction and a gunmetal impulse turbine wheel produces the energy to power the 12v 55w Tungsten Halogen bulb.

A clean dry air supply is a condition of certification and essential for the efficient running of these lamps. Deposits of dirt on the inside of the lens will adversely affect the level of illumination and if needed, air-line filters can be supplied. Another mandatory requirement of safe use is anti-static hose, designed to avoid a dangerous build up of static electricity. The Airturbo has many inherent safety features, recognised by BASEEFA; effectively pressurised and purged system, protective curtain of air from the exhaust ports, instant cut-off of the lamp if the lens is broken and cooling of heat generating components. Lamps are routinely run in, tested and set to the necessary output prior to despatch.

## Features & Benefits

- Safe Compressed Air Power
- Reversed Air Safety Feature
- Pressurised and Purged System
- 55 Watt Long-life Halogen Bulb
- Economical 0.25m<sup>3</sup>/min Consumption
- Full Accessory Range Available

## Certifications

EX (NON ATEX)

# Technical Specification

<b>Product Reference</b>		<b>A-0444</b>	<b>A-0445</b>
<b>Product Description</b>		Safety Bay Lamp Compressed Air Powered	Safety Floodlamp Compressed Air Powered
<b>Code</b>		Ex s II T6	
<b>Apparatus Standards</b>		SFA 3009:1972	
<b>Type of Protection</b>		's' special protection	
<b>Area of Classification (Gas)</b>		Zones 1 and 2, Gas Groups IIA, IIB and IIC	
<b>Temp. Classification</b>		T6	
<b>Ambient Temperature</b>		-20°C to +40°C	
<b>Certificate</b>		BASEEFA Ex 78209X*	
<b>Enclosure</b>		Nickel Plated Brass and Gun-metal	
<b>Lens</b>		Ball Glass/Polycarbonate Dome	Toughened Glass (15mm)
<b>Beam Type</b>		All-around 360° Illumination	Flood (Matt Reflector) (as standard) or Spot (Polished Reflector) (to order)
<b>Light Source:</b>	<b>Part Number</b>	<b>A-1130</b>	
	<b>Type</b>	Tungsten Halogen Filament Bulb	
	<b>Volts</b>	12v	
	<b>Watts</b>	55w	
	<b>Output</b>	1000lm (at 12v)	
	<b>Life</b>	1000hrs (at 12v)	
<b>Power Source:</b>	<b>Type</b>	Compressed Air Driven Turbo-alternator	
	<b>Air Pressure</b>	4.0-8.0 bar	
	<b>Consumption</b>	0.25m <sup>3</sup> /min	
<b>Ingress Protection</b>		Once pressurised may be used under water	
<b>Weight</b>		8.2kg	12.5kg
<b>*Special Certification Conditions</b>		A clean, dry air supply must be used. Supply hose must be anti-static.	

- All information has been gathered under laboratory conditions, the user must regard the values given as approximate.
- Changes may be made to the above specification without notification, details are available on request.

## Product Dimensions

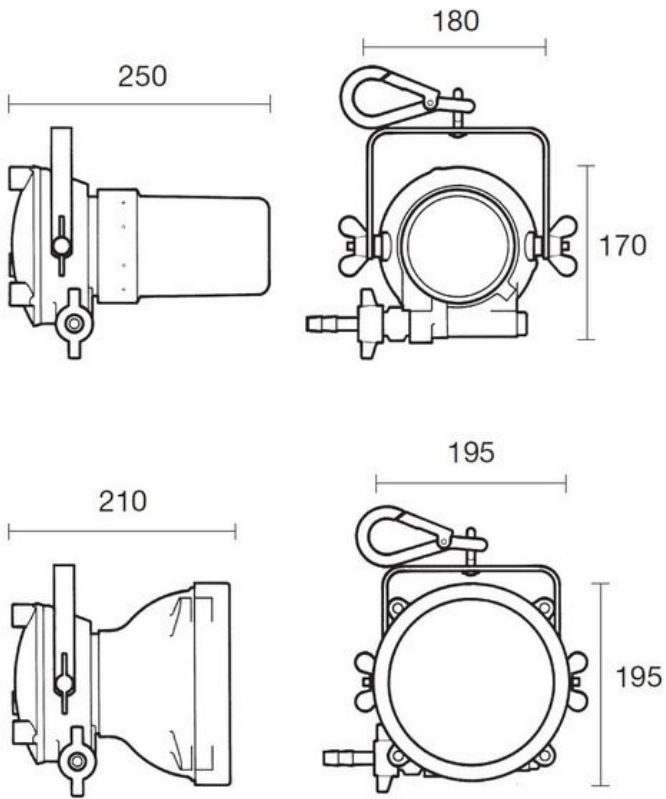

## Light Output

### A-0444 - Ball Glass

Peak luminous intensity at 2.5m radius **2lux**

### A-0445 - Polished Reflector

Spot Beam (approx 4°)

Peak luminous intensity at 5m **900lux**

### A-0445 - Matt Reflector

Flood Beam (approx 30°)

Peak luminous intensity at 5m **40lux**

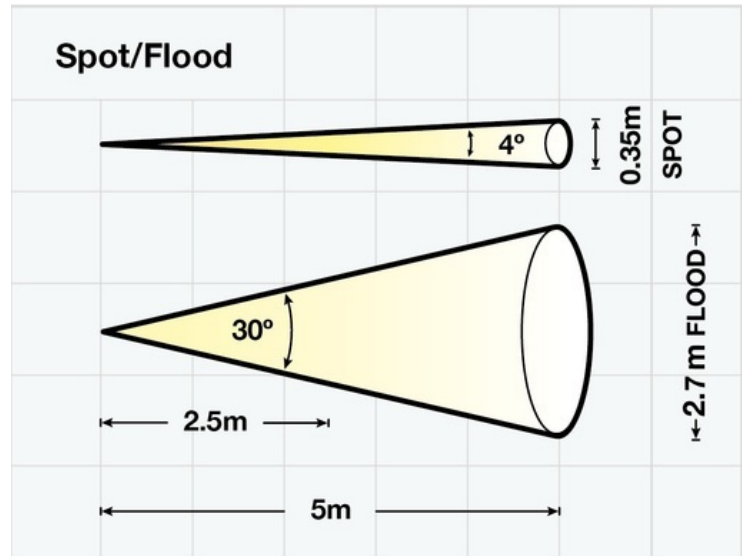

Version: SL034 DF440 Issue 3

**Wolf**®

Wolf Safety Lamp Company, Saxon Road Works, Sheffield, S8 0YA, UK

- T: +44 (0) 114 255 1051 • F: +44 (0) 114 255 7988
- E: [info@wolfsafety.com](mailto:info@wolfsafety.com) • [www.wolfsafety.com](http://www.wolfsafety.com)

